

R-LX-CS-ZP Zinc Plated Countersunk Concrete Screw Anchor

Self-tapping concrete screwbolt



Approvals and Reports

- ETA 17/0806



Product information

Features and benefits

- Time-efficient installation through streamlined procedure - simply drill and drive
- Completely removable with possibility of reuse
- Unique design with patented threadform ensures high performance for relatively small hole diameter
- Non-expansion functioning ensures low risk of damage to base material and makes R-LX ideal for installation near edges and adjacent anchors
- High performance in non-cracked concrete
- Different head types for any application
- Oversize head for fixtures with elongated holes
- Excellent product for temporary fixing
- Suitable for standard and reduced embedment depth

Applications

- Through-fixing
- Temporary anchorages
- Formwork support systems
- Balustrading & handrails
- Fencing & gates manufacturing and installation
- Racking systems
- Public seating
- Scaffolding

Base materials

Approved for use in:

- Non-cracked concrete C20/25-C50/60
- Cracked concrete C20/25-C50/60

Installation guide

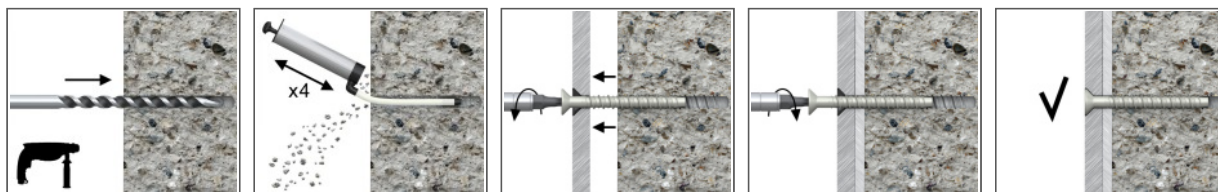

1. Drill the hole with rotary percussive machine. Drill to a required depth.
2. Blow out dust at least 4 times with a hand pump.
3. Possibility of unscrewing and re-screwing.
4. Tighten to the recommended torque.
5. After installation.

Product information

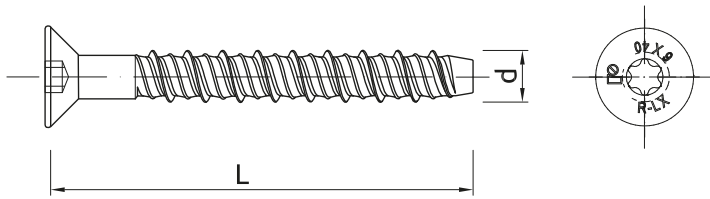

Size	Product Code	Anchor		Fixture		
		Diameter	Length	Max. thickness t_{fix} for:		Hole diameter
		d [mm]	L [mm]	$h_{nom,red}$ [mm]	$h_{nom,std}$ [mm]	d_f [mm]
5	R-LX-05X050-CS-ZP	6.3	50	-	7	7
	R-LX-05X075-CS-ZP	6.3	75	-	32	7
6	R-LX-06X050-CS-ZP	7.5	50	7	-	9
	R-LX-06X075-CS-ZP	7.5	75	32	20	9
	R-LX-06X100-CS-ZP	7.5	100	57	45	9
	R-LX-06X130-CS-ZP	7.5	130	87	75	9
	R-LX-06X150-CS-ZP	7.5	150	107	95	9
8	R-LX-08X060-CS-ZP	10	60	10	-	12
	R-LX-08X075-CS-ZP	10	75	25	5	12
	R-LX-08X090-CS-ZP	10	90	40	20	12
	R-LX-08X100-CS-ZP	10	100	50	30	12
	R-LX-08X130-CS-ZP	10	130	80	60	12
	R-LX-08X150-CS-ZP	10	150	100	80	12
10	R-LX-10X065-CS-ZP	12.5	65	10	-	14
	R-LX-10X075-CS-ZP	12.5	75	20	-	14
	R-LX-10X085-CS-ZP	12.5	85	30	-	14
	R-LX-10X100-CS-ZP	12.5	100	45	15	14
	R-LX-10X120-CS-ZP	12.5	120	65	35	14
	R-LX-10X140-CS-ZP	12.5	140	85	55	14
	R-LX-10X160-CS-ZP	12.5	160	105	75	14

Installation data

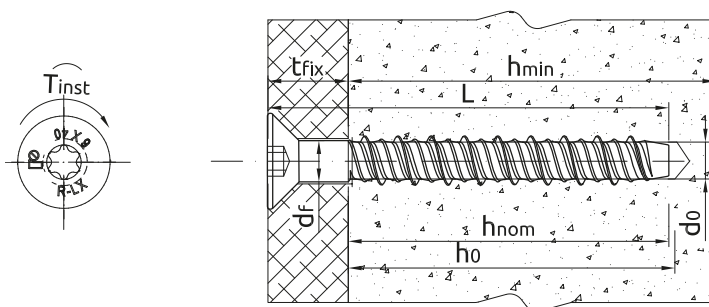

Size	5	6	8	10	
Head diameter	[mm]	10.9	13.2	17.9	21.3
Thread diameter	d [mm]	6.3	7.5	10	12.5
Hole diameter in substrate	d_o [mm]	5	6	8	10
Screw drive	- [-]	25	T30	T45	T50

Installation data

Size			5	6	8	10
STANDARD EMBEDMENT DEPTH						
Min. hole depth in substrate	$h_{0,s}$	[mm]	50	65	80	95
Installation depth	$h_{nom,s}$	[mm]	43	55	70	85
Min. substrate thickness	$h_{min,s}$	[mm]	100	100	110	130
Min. spacing	$s_{min,s}$	[mm]	40	45	50	60
Min. edge distance	$c_{min,s}$	[mm]	40	45	50	60
REDUCED EMBEDMENT DEPTH						
Min. hole depth in substrate	$h_{0,r}$	[mm]	-	50	60	65
Installation depth	$h_{nom,r}$	[mm]	-	43	50	55
Min. substrate thickness	$h_{min,r}$	[mm]	-	100	100	100
Min. spacing	$s_{min,r}$	[mm]	-	45	50	60
Min. edge distance	$c_{min,r}$	[mm]	-	45	50	60

Mechanical properties

Size			5	6	8	10
Nominal ultimate tensile strength - tension	f_{uk}	[N/mm ²]	1300	1250	1200	1050
Nominal yield strength - tension	f_{yk}	[N/mm ²]	1150	1100	1050	950
Cross sectional area - tension	A_s	[mm ²]	19.6	28.3	50.3	78.5
Elastic section modulus	W_{el}	[mm ³]	12.2	21.2	50.3	98.1
Characteristic bending resistance	$M^0_{Rk,s}$	[Nm]	19	31.8	72.4	123.6
Design bending resistance	M	[Nm]	12.67	21.2	48.27	82.4

Basic performance data

Performance data for single anchor in tension without influence of edge distance and spacing

Size			5	6	8	10
MEAN ULTIMATE LOAD						
TENSION LOAD $N_{Ru,m}$						
NON-CRACKED CONCRETE C20/25						
Standard embedment depth	[kN]	10.10	14.80	26.04	35.37	
Reduced embedment depth	[kN]	-	11.09	15.19	17.08	
CRACKED CONCRETE C20/25						
Standard embedment depth	[kN]	7.10	11.10	18.33	24.89	
Reduced embedment depth	[kN]	-	7.81	10.69	12.02	
SHEAR LOAD $V_{Ru,m}$						
NON-CRACKED CONCRETE C20/25						
Standard embedment depth	[kN]	10.10	14.80	26.04	49.46	
Reduced embedment depth	[kN]	-	11.09	15.19	17.08	
CRACKED CONCRETE C20/25						
Standard embedment depth	[kN]	7.10	11.10	18.33	49.46	
Reduced embedment depth	[kN]	-	7.81	10.69	12.02	

Basic performance data

Size		5	6	8	10
CHARACTERISTIC LOAD					
TENSION LOAD N_{Rk}					
NON-CRACKED CONCRETE C20/25					
Standard embedment depth	[kN]	7.00	12.00	19.49	26.46
Reduced embedment depth	[kN]	-	9.14	10.91	12.78
CRACKED CONCRETE C20/25					
Standard embedment depth	[kN]	4.50	7.00	13.00	18.87
Reduced embedment depth	[kN]	-	6.52	7.50	8.00
SHEAR LOAD V_{Rk}					
NON-CRACKED CONCRETE C20/25					
Standard embedment depth	[kN]	9.14	13.75	19.49	41.20
Reduced embedment depth	[kN]	-	9.14	10.91	12.78
CRACKED CONCRETE C20/25					
Standard embedment depth	[kN]	6.52	9.80	13.89	37.73
Reduced embedment depth	[kN]	-	6.52	7.78	9.11
DESIGN LOAD					
TENSION LOAD N_{Rd}					
NON-CRACKED CONCRETE C20/25					
Standard embedment depth	[kN]	3.89	8.00	12.99	17.64
Reduced embedment depth	[kN]	-	6.09	7.27	8.52
CRACKED CONCRETE C20/25					
Standard embedment depth	[kN]	2.50	4.67	8.67	12.58
Reduced embedment depth	[kN]	-	4.34	5.00	5.33
SHEAR LOAD V_{Rd}					
NON-CRACKED CONCRETE C20/25					
Standard embedment depth	[kN]	6.09	9.16	12.99	27.47
Reduced embedment depth	[kN]	-	6.09	7.27	8.52
CRACKED CONCRETE C20/25					
Standard embedment depth	[kN]	4.34	6.53	9.26	25.15
Reduced embedment depth	[kN]	-	4.34	5.18	6.07
RECOMMENDED LOAD					
TENSION LOAD N_{rec}					
NON-CRACKED CONCRETE C20/25					
Standard embedment depth	[kN]	2.78	5.71	9.28	12.60
Reduced embedment depth	[kN]	-	4.35	5.19	6.08
CRACKED CONCRETE C20/25					
Standard embedment depth	[kN]	1.79	3.33	6.19	8.98
Reduced embedment depth	[kN]	-	3.10	3.57	3.81
SHEAR LOAD V_{rec}					
NON-CRACKED CONCRETE C20/25					
Standard embedment depth	[kN]	4.35	6.55	9.28	19.62
Reduced embedment depth	[kN]	-	4.35	5.19	6.08
CRACKED CONCRETE C20/25					
Standard embedment depth	[kN]	3.10	4.67	6.61	17.97
Reduced embedment depth	[kN]	-	3.10	3.70	4.34

Design performance data

Standard embedment depth

(-) failure is not decisive

Size			5	6	8	10
Installation depth	h_{nom}	[mm]	43.00	55.00	70.00	85.00
Effective embedment depth	h_{ef}	[mm]	32.00	42.00	53.00	65.00
TENSION LOAD						
STEEL FAILURE						
Characteristic resistance	$N_{Rk,s}$	[kN]	25.50	35.40	60.40	82.40
Partial safety factor	γ_{Ms}	-	1.40	1.40	1.40	1.40
PULL-OUT FAILURE; NON-CRACKED CONCRETE C20/25						
Characteristic resistance	$N_{Rk,p}$	[kN]	7.00	12.00	-	-
PULL-OUT FAILURE; CRACKED CONCRETE C20/25						
Characteristic resistance	$N_{Rk,p}$	[kN]	4.50	7.00	13.00	-
PULL-OUT FAILURE						
Installation safety factor	γ_2	-	1.20	1.00	1.00	1.00
Increasing factors for $N_{Rd,p}$ - C30/37	ψ_c	-	1.08	1.08	1.08	1.08
Increasing factors for $N_{Rd,p}$ - C40/50	ψ_c	-	1.15	1.15	1.15	1.15
Increasing factors for $N_{Rd,p}$ - C50/60	ψ_c	-	1.19	1.19	1.19	1.19
CONCRETE CONE FAILURE						
Installation safety factor	γ_2	-	1.20	1.00	1.00	1.00
Factor for cracked concrete	k	-	7.20	7.20	7.20	7.20
Factor for cracked concrete	$k_{cr,N}$	-	7.70	7.70	7.70	7.70
Factor for non-cracked concrete	k	-	10.10	10.10	10.10	10.10
Factor for non-cracked concrete	$k_{gr,N}$	-	11.00	11.00	11.00	11.00
Spacing	$s_{cr,N}$	[mm]	90.00	126.00	160.00	196.00
Edge distance	$c_{cr,N}$	[mm]	45.00	63.00	80.00	98.00
CONCRETE SPLITTING FAILURE						
Installation safety factor	γ_2	-	1.20	1.00	1.00	1.00
Spacing	$s_{cr,sp}$	[mm]	90.00	126.00	160.00	222.00
Edge distance	$c_{cr,sp}$	[mm]	45.00	63.00	80.00	111.00
SHEAR LOAD						
STEEL FAILURE						
Characteristic resistance without lever arm	$V_{Rk,s}$	[kN]	12.70	17.70	30.20	41.20
Ductility factor	k_γ	-	0.80	0.80	0.80	0.80
Characteristic resistance with lever arm	$M_{Rk,s}$	[Nm]	19.00	31.80	72.40	123.60
Partial safety factor	γ_{Ms}	-	1.50	1.50	1.50	1.50
CONCRETE PRY-OUT FAILURE						
Factor	k	-	1.00	1.00	1.00	2.00
Installation safety factor	γ_2	-	1.00	1.00	1.00	1.00
CONCRETE EDGE FAILURE						
Effective length of anchor	l_f	[mm]	32.00	42.00	53.00	65.00
Anchor diameter	d_{nom}	[mm]	6.00	6.00	8.00	10.00
Installation safety factor	γ_2	-	1.00	1.00	1.00	1.00

Design performance data

Characteristic Resistance under fire exposure in concrete C20/25 to C50/60

Size			5	6	8	10
TENSION LOAD						
Edge distance	c_{cr}	[mm]	64.00	84.00	106.00	130.00
Spacing	s_{cr}	[mm]	128.00	168.00	212.00	260.00
R (for EI) = 30 min						
TENSION LOAD						
STEEL FAILURE						
Characteristic resistance	$N_{Rk,s}$	[kN]	0.20	0.28	0.75	1.57
PULL-OUT FAILURE						
Characteristic resistance	$N_{Rk,p}$	[kN]	1.13	1.75	3.25	4.75
SHEAR LOAD						
STEEL FAILURE						
Characteristic resistance without lever arm	$V_{Rk,s}$	[kN]	0.20	0.28	0.75	1.57
Characteristic resistance with lever arm	$M_{Rk,s}$	[Nm]	0.15	0.25	0.90	2.36
R (for EI) = 60 min						
TENSION LOAD						
STEEL FAILURE						
Characteristic resistance	$N_{Rk,s}$	[kN]	0.18	0.25	0.65	1.18
PULL-OUT FAILURE						
Characteristic resistance	$N_{Rk,p}$	[kN]	1.13	1.75	3.25	4.75
SHEAR LOAD						
STEEL FAILURE						
Characteristic resistance without lever arm	$V_{Rk,s}$	[kN]	0.18	0.25	0.65	1.18
Characteristic resistance with lever arm	$M_{Rk,s}$	[Nm]	0.13	0.23	0.78	1.77
R (for EI) = 90 min						
TENSION LOAD						
STEEL FAILURE						
Characteristic resistance	$N_{Rk,s}$	[kN]	0.14	0.20	0.50	1.02
PULL-OUT FAILURE						
Characteristic resistance	$N_{Rk,p}$	[kN]	1.13	1.75	3.25	4.75
SHEAR LOAD						
STEEL FAILURE						
Characteristic resistance without lever arm	$V_{Rk,s}$	[kN]	0.14	0.20	0.50	1.02
Characteristic resistance with lever arm	$M_{Rk,s}$	[Nm]	0.10	0.18	0.60	1.53
R (for EI) = 120 min						
TENSION LOAD						
STEEL FAILURE						
Characteristic resistance	$N_{Rk,s}$	[kN]	0.10	0.14	0.40	0.79
PULL-OUT FAILURE						
Characteristic resistance	$N_{Rk,p}$	[kN]	0.90	1.40	2.60	3.80
SHEAR LOAD						
STEEL FAILURE						
Characteristic resistance without lever arm	$V_{Rk,s}$	[kN]	0.10	0.14	0.40	0.79
Characteristic resistance with lever arm	$M_{Rk,s}$	[Nm]	0.07	0.13	0.48	1.18

Design performance data

Reduced embedment depth

(-) failure is not decisive

Size			5	6	8	10
Installation depth	h_{nom}	[mm]	-	43.00	50.00	55.00
Effective embedment depth	h_{ef}	[mm]	-	32.00	36.00	40.00
TENSION LOAD						
STEEL FAILURE						
Characteristic resistance	$N_{Rk,s}$	[kN]	-	35.40	60.40	82.40
Partial safety factor	γ_{Ms}	-	-	1.40	1.40	1.40
PULL-OUT FAILURE; NON-CRACKED CONCRETE C20/25						
Characteristic resistance	$N_{Rk,p}$	[kN]	-	-	-	-
PULL-OUT FAILURE; CRACKED CONCRETE C20/25						
Characteristic resistance	$N_{Rk,p}$	[kN]	-	-	7.50	8.00
PULL-OUT FAILURE						
Installation safety factor	γ_2	-	-	1.00	1.00	1.00
Increasing factors for $N_{Rd,p}$ - C30/37	ψ_c	-	-	1.08	1.08	1.08
Increasing factors for $N_{Rd,p}$ - C40/50	ψ_c	-	-	1.15	1.15	1.15
Increasing factors for $N_{Rd,p}$ - C50/60	ψ_c	-	-	1.19	1.19	1.19
CONCRETE CONE FAILURE						
Installation safety factor	γ_2	-	-	1.00	1.00	1.00
Factor for cracked concrete	k	-	-	7.20	7.20	7.20
Factor for cracked concrete	$k_{cr,N}$	-	-	7.70	7.70	7.70
Factor for non-cracked concrete	k	-	-	10.10	10.10	10.10
Factor for non-cracked concrete	$k_{gr,N}$	-	-	11.00	11.00	11.00
Spacing	$s_{cr,N}$	[mm]	-	90.00	112.00	120.00
Edge distance	$c_{cr,N}$	[mm]	-	45.00	56.00	60.00
CONCRETE SPLITTING FAILURE						
Installation safety factor	γ_2	-	-	1.00	1.00	1.00
Spacing	$s_{cr,sp}$	[mm]	-	90.00	112.00	136.00
Edge distance	$c_{cr,sp}$	[mm]	-	45.00	56.00	68.00
SHEAR LOAD						
STEEL FAILURE						
Characteristic resistance without lever arm	$V_{Rk,s}$	[kN]	-	17.70	30.20	41.20
Ductility factor	k_γ	-	-	0.80	0.80	0.80
Characteristic resistance with lever arm	$M_{Rk,s}$	[Nm]	-	31.80	72.40	123.60
Partial safety factor	γ_{Ms}	-	-	1.50	1.50	1.50
CONCRETE PRY-OUT FAILURE						
Factor	k	-	-	1.00	1.00	1.00
Installation safety factor	γ_2	-	-	1.00	1.00	1.00
CONCRETE EDGE FAILURE						
Effective length of anchor	l_f	[mm]	-	32.00	36.00	40.00
Anchor diameter	d_{nom}	[mm]	-	6.00	8.00	8.00
Installation safety factor	γ_2	-	-	1.00	1.00	1.00

Design performance data

Characteristic Resistance under fire exposure in concrete C20/25 to C50/60

Size			5	6	8	10
TENSION LOAD						
Edge distance	c_{cr}	[mm]	-	84.00	72.00	80.00
Spacing	s_{cr}	[mm]	-	168.00	144.00	160.00
R (for EI) = 30 min						
TENSION LOAD						
STEEL FAILURE						
Characteristic resistance	$N_{Rk,s}$	[kN]	-	0.28	0.75	1.57
PULL-OUT FAILURE						
Characteristic resistance	$N_{Rk,p}$	[kN]	-	1.38	1.88	2.00
SHEAR LOAD						
STEEL FAILURE						
Characteristic resistance without lever arm	$V_{Rk,s}$	[kN]	-	0.28	0.75	1.57
Characteristic resistance with lever arm	$M_{Rk,s}$	[Nm]	-	0.25	0.90	2.36
R (for EI) = 60 min						
TENSION LOAD						
STEEL FAILURE						
Characteristic resistance	$N_{Rk,s}$	[kN]	-	0.25	0.65	1.18
PULL-OUT FAILURE						
Characteristic resistance	$N_{Rk,p}$	[kN]	-	1.38	1.88	2.00
SHEAR LOAD						
STEEL FAILURE						
Characteristic resistance without lever arm	$V_{Rk,s}$	[kN]	-	0.25	0.65	1.18
Characteristic resistance with lever arm	$M_{Rk,s}$	[Nm]	-	0.23	0.78	1.77
R (for EI) = 90 min						
TENSION LOAD						
STEEL FAILURE						
Characteristic resistance	$N_{Rk,s}$	[kN]	-	0.20	0.50	1.02
PULL-OUT FAILURE						
Characteristic resistance	$N_{Rk,p}$	[kN]	-	1.38	1.88	2.00
SHEAR LOAD						
STEEL FAILURE						
Characteristic resistance without lever arm	$V_{Rk,s}$	[kN]	-	0.20	0.50	1.02
Characteristic resistance with lever arm	$M_{Rk,s}$	[Nm]	-	0.18	0.60	1.53
R (for EI) = 120 min						
TENSION LOAD						
STEEL FAILURE						
Characteristic resistance	$N_{Rk,s}$	[kN]	-	0.14	0.40	0.79
PULL-OUT FAILURE						
Characteristic resistance	$N_{Rk,p}$	[kN]	-	1.10	1.50	1.60
SHEAR LOAD						
STEEL FAILURE						
Characteristic resistance without lever arm	$V_{Rk,s}$	[kN]	-	0.14	0.40	0.79
Characteristic resistance with lever arm	$M_{Rk,s}$	[Nm]	-	0.13	0.48	1.18

Product commercial data

Size	Product Code	Anchor	Quantity [pcs]			Weight [kg]			Bar Codes
		Length [mm]	Box	Outer	Pallet	Box	Outer	Pallet	
5	R-LX-05X050-CS-ZP ¹⁾	50	100	100	41600	0.10	0.10	71.6	5906675127859
	R-LX-05X075-CS-ZP ¹⁾	75	100	100	41600	0.10	0.10	71.6	5906675128054
6	R-LX-06X050-CS-ZP ¹⁾	50	100	100	41600	0.10	0.10	71.6	5906675128801
	R-LX-06X075-CS-ZP ¹⁾	75	100	100	41600	1.83	1.83	792.9	5906675129280
	R-LX-06X100-CS-ZP ¹⁾	100	100	100	25600	2.4	2.4	649.8	5906675129297
	R-LX-06X130-CS-ZP ¹⁾	130	100	100	25600	3.1	3.1	819.5	5906675129303
	R-LX-06X150-CS-ZP ¹⁾	150	100	100	25600	0.10	0.10	55.6	5906675129310
	R-LX-08X060-CS-ZP ¹⁾	60	100	100	25600	0.10	0.10	55.6	5906675129327
8	R-LX-08X075-CS-ZP ¹⁾	75	100	100	25600	3.3	3.3	879.2	5906675129334
	R-LX-08X090-CS-ZP ¹⁾	90	100	100	19200	3.9	3.9	783.4	5906675129341
	R-LX-08X100-CS-ZP ¹⁾	100	100	100	19200	4.3	4.3	862.3	5906675129358
	R-LX-08X130-CS-ZP ¹⁾	130	50	50	12800	2.8	2.8	743.0	5906675129365
	R-LX-08X150-CS-ZP ¹⁾	150	50	50	12800	0.05	0.05	42.8	5906675129372
	R-LX-10X065-CS-ZP ¹⁾	65	50	50	15600	0.05	0.05	45.6	5906675129389
10	R-LX-10X075-CS-ZP ¹⁾	75	50	50	12800	0.05	0.05	42.8	5906675129396
	R-LX-10X085-CS-ZP ¹⁾	85	50	50	12800	0.05	0.05	42.8	5906675129402
	R-LX-10X100-CS-ZP ¹⁾	100	50	50	12800	0.05	0.05	42.8	5906675129419
	R-LX-10X120-CS-ZP ¹⁾	120	25	25	6400	0.03	0.03	36.4	5906675129426
	R-LX-10X140-CS-ZP ¹⁾	140	25	25	7800	0.03	0.03	37.8	5906675129433
	R-LX-10X160-CS-ZP ¹⁾	160	20	20	6240	0.02	0.02	36.2	5906675129440

1) ETA 17/0806